

Vertical Bladder Tank

Balanced Pressure Foam Supply Device

- Range of Capacities 200 litres - 10,000 litres
- Perfect For Tight Spaces
- UL/ASME Approved
- Interior Strainers And Flow Path Devices Integral To Tank
- Compatible With All Foam Proportioners / Ratio Controllers



The Bladder Tank is an integral component of the bladder tank proportioning system, which requires no external power other than an adequate water supply. A bladder tank, with an appropriate proportioner(s), injects foam concentrate into the water supply of a fire protection system and automatically proportions over a wide range of flows and pressures.

The Angus Fire bladder tank is a steel pressure vessel fitted with an internal bladder that stores foam concentrate. During operation, water supplied to the bladder tank displaces the foam concentrate and collapses the bladder until the concentrate is depleted. The bladder tank discharges foam concentrate at approximately the same pressure as the water supplied at the water inlet connection to the tank. As the bladder tank is pressurised, the bladder cannot be refilled during operation.

Features

- Compatible with all foam concentrates
- Reliable water powered foam supply
- Supplied with ladder at 2,500 litres capacity and above
- Permanently welded lifting lugs for easy tank movement and positioning

Applications

Suitable for hazardous areas such as:

- Flammable liquid storage tanks in refineries and petrochemical units
- Chemical process plants
- Aircraft hangars
- Loading and Unloading gantries
- Oil Jetties
- Off-Shore Platforms
- Warehouses
- Foam application through spray nozzle and foam sprinklers
- Municipal applications.

Approvals and Listings

Underwriters Laboratories, Inc. (UL)
CE Marked

Technical Specifications

The bladder tank is an ASME code welded carbon steel pressure vessel with a working pressure of 175 psi (12 bar). The tank is supplied in the vertical configuration and is mounted on four leg supports. The tank internals are coal tar epoxy coated. The tank is fitted with bladder vent and bladder drain valves, vessel vent and vessel drain valves all in chrome plated brass. A flexible, nylon reinforced nitrile rubber internal bladder separates the foam concentrate from the incoming water. The bladder is manufactured with single piece compression moulded neck flanges.

All external piping is Schedule 40, and is stainless steel for foam concentrate and carbon steel for water, all hydrotested to 18 bar and externally coated with fire-red epoxy paint. Ball valves, of the locking handle type for valve supervision, are supplied. Tank includes all necessary drain and vent valves. External surfaces of tank and piping are coated red epoxy paint to RAL 3000.

Technical Information

Materials of Construction:

Tank: Carbon steel, ASME code

Bladder: Welded Seam Nylon reinforced nitrile rubber (Buna-N)

External Piping: Water Side: Carbon Steel, Sch. 40, Screwed, Fm. Conc.
Side: stainless steel

Valves: Ball valve with locking handle

Exterior Finish: RAL 3000 fire red

Working Pressure: 175 psi (12 bar)

Options

- Sight gauge: Tube type lever indicator
- Special finishes
- Prepiped
- Alternate discharge directions
- Option of vent and drain valves in stainless steel 316
- Pressure relief valves

Vertical Bladder Tank

Balanced Pressure Foam Supply Device

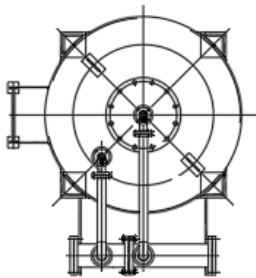
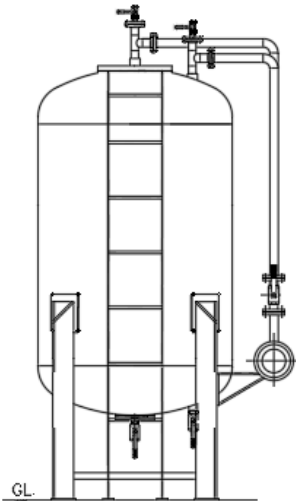
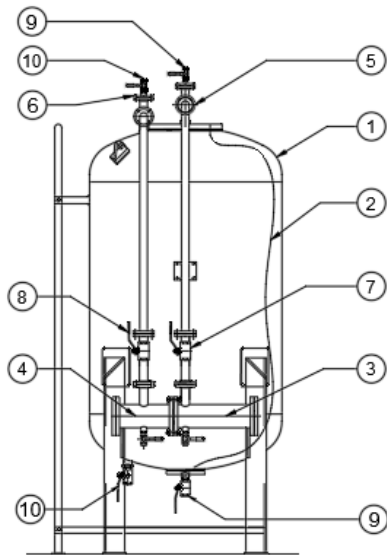

Material of Construction

Description	Material
1 Foam Vessel	Carbon Steel
2 Foam Bladder	Nylon Reinforced Nitrile Rubber
3 Foam Proportioner	Carbon Steel with Stainless Steel Intls.
4 Spool Piece	Carbon Steel
5 Foam Piping	Stainless Steel 304
6 Water Piping	Carbon Steel
7 Foam Supply Valve	Stainless Steel 304
8 Water Charging Valve	Stainless Steel 304
9 Bladder Vent/Bladder Drain	Chrome Plated Brass
10 Vessel Vent / Vessel Drain	Chrome Plated Brass
11 Thermal Expansion Relief Valve	Copper Alloy/Stainless Steel

Technical Data

1. Angus Vertical Bladder Tank # (#indicates capacity of foam vessel in litres)
2. Capacity - 200 litres to 10,000 litres
3. Design code - Asme sec.VIII Div.I Latest edition (optional - Asme U Stamp)
4. Maximum Working Pressure - 12.06 Bar (175 psi)
5. Hydrostatic Test Pressure - 18.09 Bar (263 psi)
6. Finish a) Internal - Coal Tar Epoxy b) External - Painted Epoxy Fire Red to Shade RAL 3000

Ordering Information

1. Size
2. Max working pressure
3. Flange drilling (Foam Proportioner)
4. Flow Direction - Left to Right/Right to Left
5. Optional requirement
6. Quantity

Notes:

- All dimensions are approximate and may vary slightly.
- Weights listed apply to empty tanks.
- When designing a building to house bladder tanks, provisions must be made to allow for the removal of the internal piping and bladder. These items are the full length and height of tank.
- End user shall supply a pressure relief valve to ensure pressure at inlet to bladder tank is not more than 12 bar.
- For non-standard or special tanks, refer to the tank's specific outline assembly drawing for details.

Vertical Bladder Tank - Prepiped

Dimensional Data

Size		A	B	C	Foam Proportioner															G	Empty Weight (kgs)
					50NB			80NB			100NB			150NB			200NB				
Liters	Gallons				D	E	F	D	E	F	D	E	F	D	E	F	D	E	F		
200	53	612	1773	425	530	837	225	540	847	235	550	857	245	570	877	265	----	----	----	600	350
300	79	612	2163	425	530	837	225	540	847	235	550	857	245	570	877	265	----	----	----	600	400
400	106	612	2553	425	530	837	225	540	847	235	550	857	245	570	877	265	----	----	----	600	440
500	132	816	2119	565	633	1041	225	643	1051	235	653	1061	245	673	1081	265	----	----	----	600	550
600	159	816	2339	565	633	1041	225	643	1051	235	653	1061	245	673	1081	265	----	----	----	1000	590
700	185	816	2558	565	633	1041	225	643	1051	235	653	1061	245	673	1081	265	----	----	----	1000	635
800	211	816	2779	565	633	1041	225	643	1051	235	653	1061	245	673	1081	265	----	----	----	1000	675
900	238	816	2999	565	633	1041	225	643	1051	235	653	1061	245	673	1081	265	----	----	----	1000	725
1000	264	1016	2459	705	733	1241	225	743	1251	235	753	1261	245	773	1281	265	----	----	----	1000	700
1250	330	1016	2814	705	733	1241	225	743	1251	235	753	1261	245	773	1281	265	----	----	----	1000	780
1500	396	1016	3164	705	733	1241	225	743	1251	235	753	1261	245	773	1281	265	----	----	----	1000	860
1750	462	1120	3087	780	785	1345	225	795	1355	235	805	1365	245	825	1385	265	----	----	----	1000	1025
2000	528	1120	3377	780	785	1345	225	795	1355	235	805	1365	245	825	1385	265	----	----	----	1000	1125
2500	660	1320	3228	920	885	1545	225	895	1555	235	905	1565	245	925	1585	265	960	1620	300	1000	1450
3000	793	1320	3643	920	885	1545	225	895	1555	235	905	1565	245	925	1585	265	960	1620	300	1000	1605
3500	925	1320	4058	920	885	1545	225	895	1555	235	905	1565	245	925	1585	265	960	1620	300	1000	1760
4000	1057	1570	3532	1095	1010	1795	225	1020	1805	235	1030	1815	245	1050	1835	265	1085	1870	300	1000	1855
4500	1189	1570	3824	1095	1010	1795	225	1020	1805	235	1030	1815	245	1050	1835	265	1085	1870	300	1000	1895
5000	1321	1570	4117	1095	1010	1795	225	1020	1805	235	1030	1815	245	1050	1835	265	1085	1870	300	1000	2020
5500	1453	1570	4402	1095	1010	1795	225	1020	1805	235	1030	1815	245	1050	1835	265	1085	1870	300	1000	2125
6000	1585	1824	3837	1275	1137	2049	225	1147	2059	235	1157	2069	245	1177	2089	265	1212	2124	300	1000	2530
7000	1849	1824	4272	1275	1137	2049	225	1147	2059	235	1157	2069	245	1177	2089	265	1212	2124	300	1000	2780
8000	2114	1824	4702	1275	1137	2049	225	1147	2059	235	1157	2069	245	1177	2089	265	1212	2124	300	1000	3030
9000	2378	1824	5137	1275	1137	2049	225	1147	2059	235	1157	2069	245	1177	2089	265	1212	2124	300	1000	3300
10000	2642	1824	5567	1275	1137	2049	225	1147	2059	235	1157	2069	245	1177	2089	265	1212	2124	300	1000	3540

Packing Dimensions

Size		Gross Weight (kgs)	Packing Dimensions (mm)		
Liters	Gallons		L	W	H
200	53	565	2020	1100	1000
300	79	650	2500	1100	1000
400	106	715	2850	1100	1000
500	132	845	2400	1250	1200
600	159	900	2600	1250	1200
700	185	970	2850	1250	1200
800	211	1025	3000	1250	1200
900	238	1100	3300	1250	1200
1000	264	1080	2650	1450	1400
1250	330	1205	3050	1450	1400
1500	396	1325	3450	1450	1400
1750	462	1525	3400	1550	1500
2000	528	1660	3700	1550	1500
2500	660	2050	3550	1750	1700
3000	793	2255	3950	1750	1700
3500	925	2460	4350	1750	1700
4000	1057	2590	3850	1950	1950
4500	1189	2670	4150	1950	1950
5000	1321	2840	4450	1950	1950
5500	1453	2985	4700	1950	1950
6000	1585	3440	4150	2250	2200
7000	1849	3765	4600	2250	2200
8000	2114	4085	5000	2250	2200
9000	2378	4430	5450	2250	2200
10000	2642	4745	5900	2250	2200

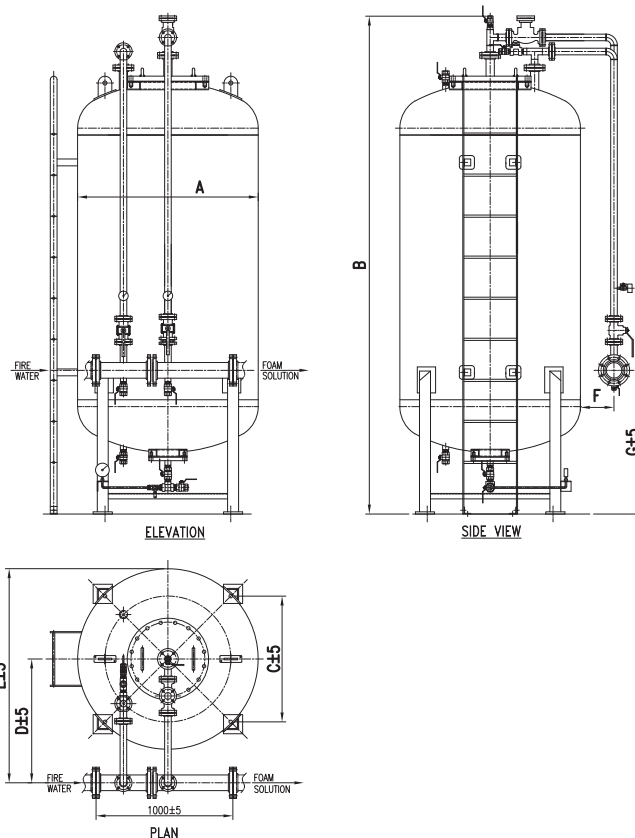

Notes:

1. All dimensions are in mm, unless otherwise specified.



Vertical Bladder Tank - Non-Prepiped

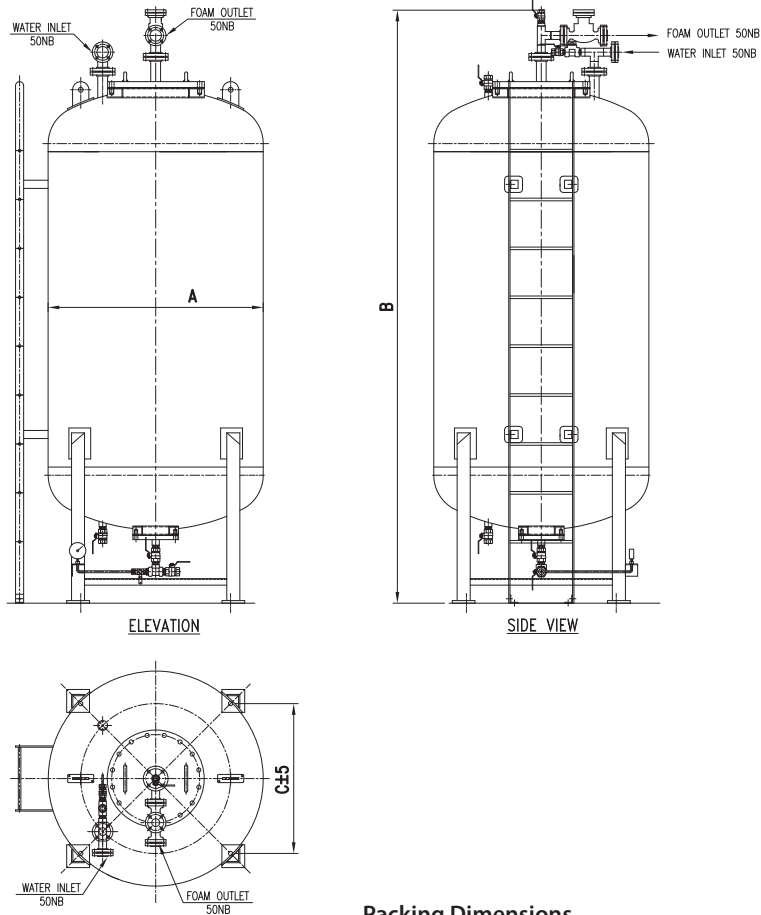

Dimensional Data

Size		A	B	C	Empty Weight (kgs)
Liters	Gallons				
200	53	612	1773	425	215
300	79	612	2163	425	255
400	106	612	2553	425	295
500	132	816	2119	565	410
600	159	816	2339	565	450
700	185	816	2558	565	490
800	211	816	2779	565	530
900	238	816	2999	565	575
1000	264	1016	2459	705	565
1250	330	1016	2814	705	640
1500	396	1016	3164	705	720
1750	462	1120	3087	780	885
2000	528	1120	3377	780	975
2500	660	1320	3228	920	1215
3000	793	1320	3643	920	1365
3500	925	1320	4058	920	1515
4000	1057	1570	3532	1095	1615
4500	1189	1570	3824	1095	1650
5000	1321	1570	4117	1095	1770
5500	1453	1570	4402	1095	1870
6000	1585	1824	3837	1275	2285
7000	1849	1824	4272	1275	2530
8000	2114	1824	4702	1275	2770
9000	2378	1824	5137	1275	3030
10000	2642	1824	5567	1275	3265

Packing Dimensions

Size		Gross Weight (kgs)	Packing Dimensions (mm)		
Liters	Gallons		L	W	H
200	53	405	2020	900	1000
300	79	480	2500	900	1000
400	106	545	2850	900	1000
500	132	685	2400	1100	1200
600	159	740	2600	1100	1200
700	185	800	2850	1100	1200
800	211	855	3000	1100	1200
900	238	925	3300	1100	1200
1000	264	925	2650	1300	1400
1250	330	1040	3050	1300	1400
1500	396	1160	3450	1300	1400
1750	462	1355	3400	1400	1500
2000	528	1475	3700	1400	1500
2500	660	1785	3550	1600	1700
3000	793	1980	3950	1600	1700
3500	925	2240	4350	1600	1700
4000	1057	2325	3850	1850	1950
4500	1189	2405	4150	1850	1950
5000	1321	2570	4450	1850	1950
5500	1453	2705	4700	1850	1950
6000	1585	3175	4150	2150	2200
7000	1849	3490	4600	2150	2200
8000	2114	3795	5000	2150	2200
9000	2378	4130	5450	2150	2200
10000	2642	4440	5900	2150	2200

Notes:

1. All dimensions are in mm, unless otherwise specified.

Foam Proportioning Unit Bladder Type

Bladder Tank Foam Proportioner / Ratio Controller

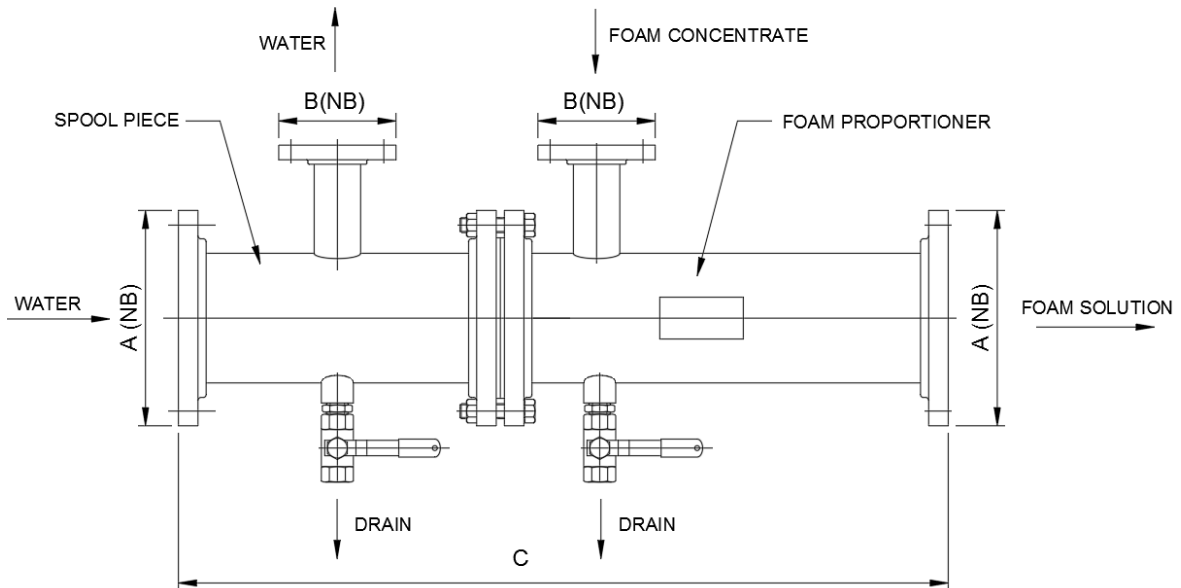

Foam proportioner and spool piece are made of carbon steel with stainless steel internals. Optional complete stainless steel units are available. Units are fully hydrotested to 18 bar and tested for flow rates and proportioning ratios for the various flows specified below. All proportioners are internally coal tar epoxy coated and finished externally with a fire red epoxy paint. Interconnecting foam and water piping is available as an option. Please specify when ordering.

Material of Construction

Description	Material
1 Body	Carbon Steel / Stainless Steel
2 Water Nozzle	Stainless Steel
3 Foam Nozzle	Stainless Steel
4 Drain Valve	Stainless Steel

Technical Data

1. Model - AFP
2. Approval - UL Listed with AFFF 3% & AR-AFFF 3 x 3% (UL File No. EX15733)
3. Maximum Working Pressure - 12.06 Bar (175 psi)
4. Foam Proportioning Ratio - 3% with AFFF & AR-AFFF Foam Concentrate
5. Hydraulic Test Pressure - 18.09 Bar (263 psi)
6. Flange Drilling - As per ANSI B16.5 150#, RF
7. Finish - Internal - Coal Tar Epoxy
8. Finish - External - Epoxy Fire Red to Shade RAL 3000

Notes:

- All dimensions are in mm. unless otherwise stated
- *Flow range is nominal flow range, for flow range with specific foam concentrate.

Performance & Dimensional Data

Model Size (NB)	Nominal Flow Range lpm*	Prop. Ratio %	A (NB)	B (NB)	C
AFP-50	75 - 1000	3%	50	25	1000
AFP-80	200 - 3200	3%	80	40	1000
AFP-100	400 - 6200	3%	100	40	1000
AFP-150	1000 - 11500	3%	150	50	1000
AFP-200	3000 - 20000	3%	200	65	1000

SALES & MARKETING

Angus Fire Ltd
Angus House, Haddenham Business Park,
Pegasus Way, Haddenham, Aylesbury, HP17 8LB, UK
Tel: +44 (0)1844 293600 • Fax: +44 (0)1844 293664

MANUFACTURING PLANT

Angus Fire Ltd
Station Road, Bentham, Lancaster, LA2 7NA, UK
Tel: +44 (0)1524 264000 • Fax: +44 (0)1524 264180

Angus Fire operates a continuous programme of product development. The right is therefore reserved to modify any specification without prior notice and Angus Fire should be contacted to ensure that the current issues of all technical data sheets are used.

© Angus Fire
6891/1 11/18