

# Foam Top Pourer Set Mk5



The Angus Fire Top Pourer Set (TPS) Mk5 is designed for use in foam systems for the protection of fixed roof flammable liquid storage tanks and combines foam generation, vapour sealing and foam pouring in a robust, low-maintenance design. The TPS Mk5 represents over 35 years of product development and operating experience. Modern materials such as graphite and stainless steel are employed to ensure each unit performs to the precise pressure and flow standards laid down by Underwriters Laboratories (UL) and NFPA.

### Key Features

- Narrow pressure tolerance bursting disc for increased reliability
- Impregnated graphite bursting disc for leak free operation
- Reusable bursting disc holder
- Air/liquid flow controller for optimum foam quality
- Body lid retained by stainless steel swing bolts for increased safety
- Captive foam enhancer for ease of access and maximum foam quality
- Integral one piece construction, including deflector, for quick and reliable installation
- Heavy duty welded construction to minimise distortion during operation

Units without a vapour seal are also available for total flooding of open roof tanks.

Four basic body sizes cover flow ranges from 75 l/min (20 US gal/min) to 3,300 l/min (870 US gal/min) at inlet pressures between 3 bar (45 psi) and 10 bar (150 psi).

The discharge is enhanced by a deflector plate fitted to the outlet which disperses the finished foam against the tank wall.

This ensures a rapid spread across the surface of the fuel, whilst lowering the application velocity, reducing contamination of the foam by the fuel and minimising splash.

### Foam Tube Length

The length of the foam dispersal tube projecting into the tank interior can be specified by the customer. The standard or minimum length of the foam dispersal tube "E" is designed for pourers mounted (usually using the Angus Fire mounting kit) directly on to the tank wall. This positions the deflector plate at the optimum position inside the tank to spread the foam evenly around the interior.

### Angus Foam

With the correct foam concentrate, Top Pourer Sets can be used in applications involving either hydrocarbon or water miscible fuels. Angus Tankmaster foam is recommended for hydrocarbon fuels and Angus Alcolseal or Tridol ATF for polar solvent chemicals.

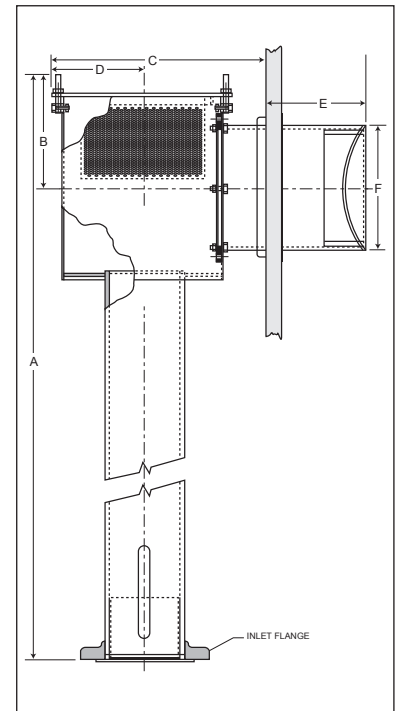

### TPS Mk5 Dimensions (mm)

	A	B	C	D	E (Min)	F	Weight (kg)
TPS 50	950	150	320	120	143	114.3	27
TPS 80	1,100	200	320	120	148	168.3	53
TPS 100	1,350	200	395	120	167	219.1	75
TPS 150	1,700	250	495	195	167	273.0	112

### ANSI RF #150 inlet / outlet flange sizes\*

	Inlet	outlet
TPS 50	2"	4"
TPS 80	3"	6"
TPS100	4"	8"
TPS150	6"	10"

\*ISO and DIN flanges also available

For detailed installation information refer to technical drawing:

Mk 5 Model	Standard style	Split flange style
TPS 50	D-B2258C1	D-B2589C1
TPS 80	D-B2259C1	D-B2590C1
TPS 100	D-B2260C1	D-B2582C1
TPS 150	D-B2261C1	D-B2591C1



## Approvals

All Angus flange mounted and split flange TPS Mk5 sets are Underwriters Laboratory (UL) listed using Angus foam at the minimum length of foam inlet tube shown above ("E").

## Graphite Vapour Seal Disc

TPS Mk5 units are fitted with a unique vapour seal bursting disc fabricated from impregnated graphite to seal the tank and prevent vapour loss. Graphite is used to ensure that the disc will burst when subjected to the pressure of foam entering the top chamber but will not burst during normal tank operations such as filling and discharging.

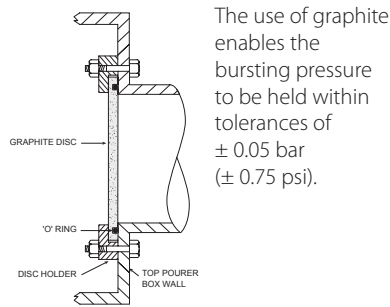

## Foam Box and Bursting Seal Access

To allow access to the foam generating box for test purposes, and to inspect or replace the graphite disc, the box lid has been designed to allow quick and easy access. Four retained stainless steel bolts swing away to allow the lid to pivot giving access without the risk of any components falling from the unit.

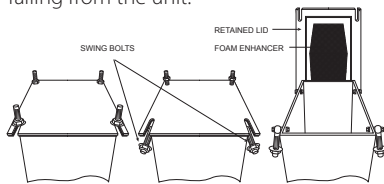

## High Pressure Tanks

The TPS Mk5 is designed for tanks where the internal pressures will not exceed 0.1 bar (1.5 psi). Where the tank is pressurised, for example with a nitrogen blanket, or where high pressures may be experienced during operation, the Angus TPS Mk4 is recommended (see data sheet 6171) with a sealing disc designed to burst at higher pressures.

## Control of the Foam/Air Mixture

To provide precise control over the ratio of foam and air the TPS Mk5 is fitted with a unique orifice plate assembly.

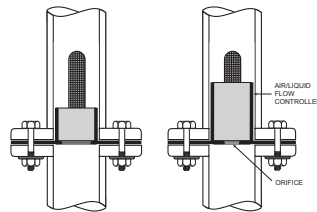

Each orifice is specifically designed to allow the correct amount of foam premix into the foam-making tube after taking into account the supply pressure at the inlet flange, the foam type and concentration.

In addition, a stainless steel sleeve, above the orifice, blocks off part of the air inlet duct ensuring the amount of air drawn into the foam generator is correct for the quantity of foam pre-mix supplied. The unique combination of orifice and sleeve ensure that optimum expansion is achieved and the foam supplied is fully utilised in the event of a fire

## Foam expansion and drainage rates

When a suitable foam concentrate is selected, the TPS can be used in applications involving either hydrocarbons or water miscible fuels. The properties of the finished foam will be dependent upon the concentrate used, but typically Angus Tankmaster, FP70, Alcolseal or Tridol ATF show expansion ratios of between 5:1 and 7:1 and a 25% drainage time of around 3 minutes at 3 bar inlet pressure up to around 8 minutes at 10 bar inlet pressure.

For applications involving water miscible fuels, Alcolseal at 6% or Tridol ATF produces a 25% drainage time of around 8 – 10 minutes at 5 bar inlet pressure to the TPS unit. Recommended application rates will vary depending on the specific water miscible product(s) involved.

## Materials and Finish

Standard bodies are fabricated from carbon steel and the orifice plate, internal parts and all fixings are manufactured from A2 or SS316 stainless steel.

Component	Material	Options
Body and foam generator tube	Carbon steel to EN10025	Stainless steel SS316
Air/Liquid flow controller	Stainless steel SS316	
High performance bursting disc	Impregnated Graphite	
Reusable bursting disc holder	Zinc plated steel	Stainless steel SS316
Bursting disc "O" ring seal	Nitrile rubber (for hydrocarbons)	Viton (for polar solvents)
Captive foam enhancer	Stainless steel SS316	
Fixings (nuts, bolts, washers)	Stainless steel 304, A2	Stainless steel SS316
Outlet flange gasket	Neoprene rubber	PTFE

Angus Fire Top Pourer Sets are supplied as standard with a unique yellow thermoplastic powder paint finish, between 250 and 450 microns thick, suitable for most operating conditions. Alternative colours are available.

## Performance Envelope

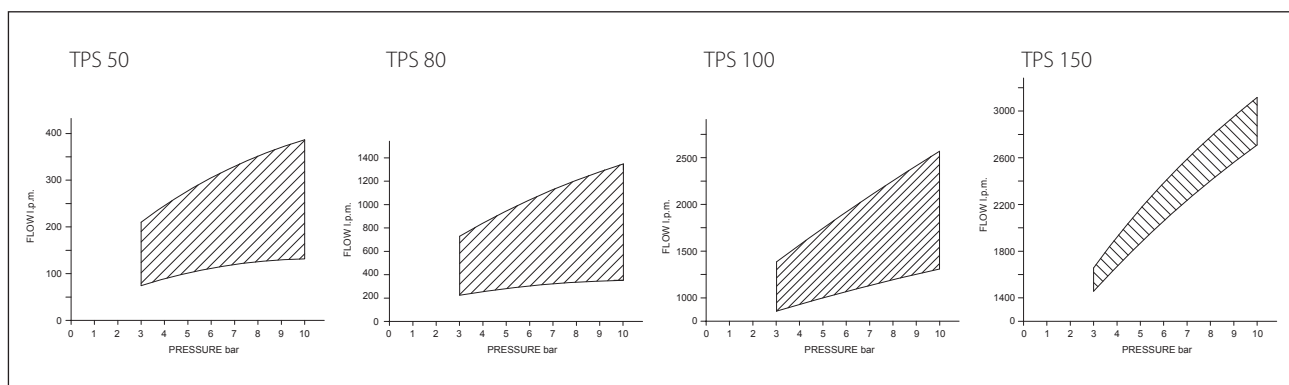

### Installation Options

The Angus mounting kit allows the TPS to be sited without the need for access from inside the tank.

**WARNING:** Before any cutting work is done to the tank wall, which could cause sparks and hot spots, it must be ensured that the tank is empty and purged of any flammable vapour.

A hole is cut into the tank side. Then the Angus mounting kit flange is secured from outside by passing the stud nuts through the access hole. They are then tightened on the inside by reaching through the access hole from outside the tank, removing the need for access to the inside of the tank. The TPS body with its foam deflector is then bolted on to the adapter kit flange in the normal way.

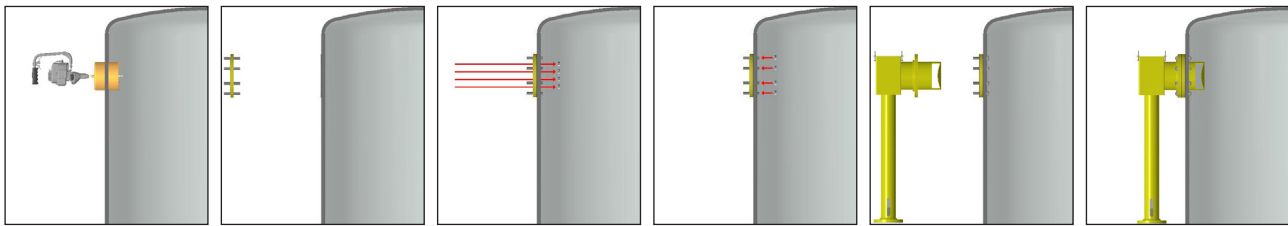

### Split Flange Installation Options

Angus TPS units can be supplied with a split flange layout to enable the unit to be mounted away from the tank side. This is intended as an option for a new tank under construction, due to the requirement to work inside the tank.

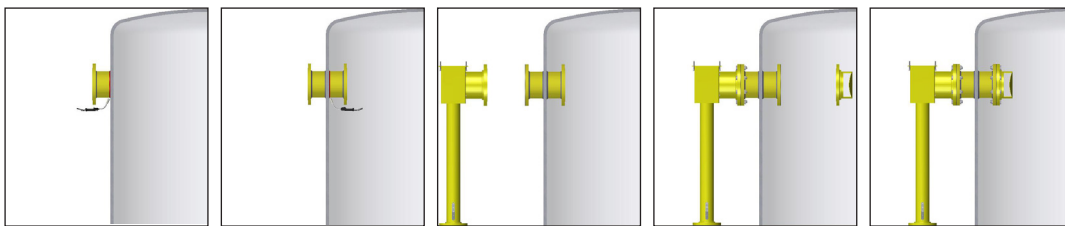

Flanges are welded outside and inside the tank wall. The TPS body and foam generator are mounted on to the external flange and the foam deflector on to the internal flange.

### Adaptor Kit Datasheet Reference

(for standard TPS installation. Not required for split flange installation as described below)

Datasheet Reference		
	ANSI Flange	DIN Flange
TPS 50	D-A3C7729	D-A3C8721
TPS 80	D-15833	D-A3C8704
TPS 100	D-15829	D-A3C8723
TPS 150	D-16057	D-A3C8725

Tank Diameter (m)	Minimum number of foam top pourers (NFPA11;2010 & EN13565-2;2009)
Up to 24	1
24 to 36	2
36 to 42	3
42 to 48	4
48 to 54	5
54 to 60	6
Over 60m	add one inlet for each additional 465m <sup>2</sup> of exposed fuel surface area (exceeding 2827m <sup>2</sup> )

#### Notes:

1. All inlets should be positioned equally around the circumference of the tank, but the distance between any 2 pourers should not exceed 30m on fixed cone roof tanks.
2. Consideration may have to be given to ensuring the foam application does reach the centre of large tanks.

Angus Fire is a company assessed to ISO 9000:2008.



FM 00215

### Angus Fire

Thame Park Road, Thame, Oxfordshire OX9 3RT, United Kingdom  
 Tel: +44 (0)1844 265000  
 Fax: +44 (0)1844 265156  
 E-mail: general.enquiries@angusuk.co.uk  
 Web: www.angusfire.co.uk

Angus Fire operates a continuous programme of product development. The right is therefore reserved to modify any specification without prior notice and Angus Fire should be contacted to ensure that the current issues of all technical data sheets are used.

© Angus Fire  
 6353/11 2.13